

SKYRC

RSTW^{PRO}

Professional Tire Warmer

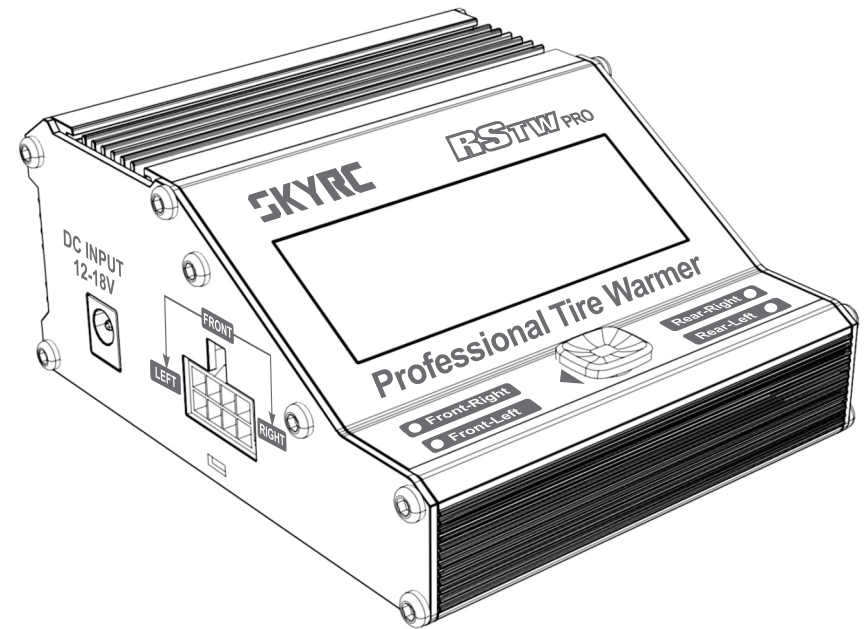

SKYRC

Manufactured by
SKYRC TECHNOLOGY CO., LTD.
www.skyrc.com

Instruction Manual

INTRODUCTION01

FEATURES02

HOW TO CONNECT TIRE WARMER TO DC POWER SOURCE03

QUICK WARMING04

STEP WARMING05

USER SET UP06

OPTIONAL PARTS07

CALIBRATION & FACTORY RESET08

LIABILITY EXCLUSION & WARRANTY09

INTRODUCTION

SKYRC Professional Tire Warmers are designed to pre-heat rubber tires for 1/10 size touring car. Using tire warmer can optimum temperature of tires before taking the car onto a track or race circuit. Having the surface rubber hot increases the co-efficient of friction of the rubber and adding to its ability to grip the track surface. Pre-heating the rubber eliminates downtime of tires building up heat naturally to attain the full performance of the tire.

Using SKYRC Tire Warmers gives you the advantage of tires being ready as soon as you roll out onto the track.

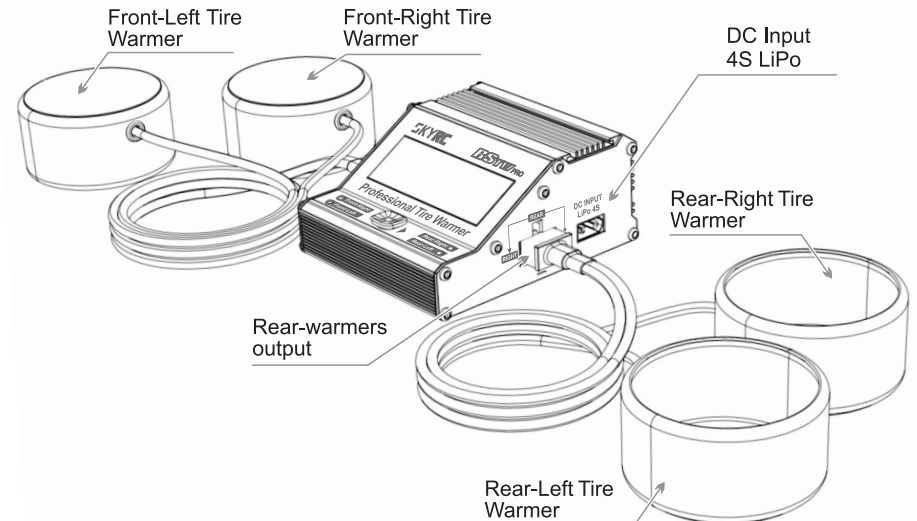
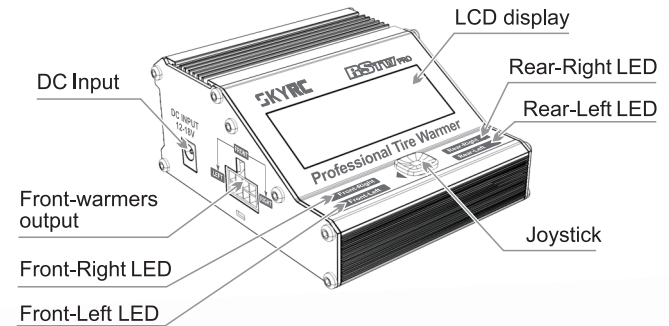

FEATURES

FEATURES

- Dual Power Source: 4S LiPo battery pack or 12-18V DC input
- Front & Rear temperature can be set independently
- Temperature of 4 tires is controlled by MCU
- Removable front & rear tire warmers
- 8 different beep tones
- Minimum temperature
- Celsius - Fahrenheit selectable display
- Four LEDs indicator
- Safety timer

SPECIFICATIONS

- Input: 12-18V or 4S LiPo Battery Pack
- Temperature Range*: 20-80°C, 100°C / 68-176°F, 212°F
- Keys: Joystick - ▲Up, ▼Down, ◀Left, ▶Right
- Dimensions: 92x111.4x50mm
- Weight: 440g / 15.52oz

* Atmospheric conditions may affect the final tire temperature

THE SET CONTAINS

1. SKYRC Tire Warmer Controller
2. Front Tire Warmers
3. Rear Tire Warmers
4. DC Input Cable

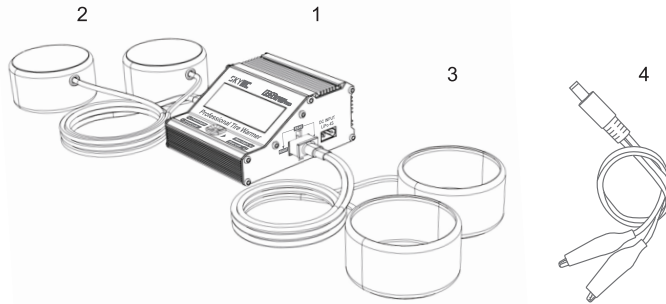

NOTES

- Fitted tire warmers must never come into contact with the ground – the car must always be elevated clear of the ground using suitable stands.
- Never use tire warmers unless they are fitted to a tire!
- Do not fit, use or remove tire warmers when the car is still power on.
- Always check the tire warmers before use, if any signs of wear or damage are noticed then they must not be used
- Never attempt to modify the warmers
- Do not leave tire warmers in use unattended
- Only for use with 1/10 scale rubber tires

HOW TO CONNECT TIRE WARMER TO DC SOURCE

HOW TO CONNECT TIRE WARMER TO DC POWER SOURCE

1. Using DC Power Source

Located on the left side of the tire warmer is a jack for the connection of the DC power cord. To utilize the tire warmer's absolute maximum capability, the DC power source must be capable of delivering at least 8 amps while maintaining 12V DC.

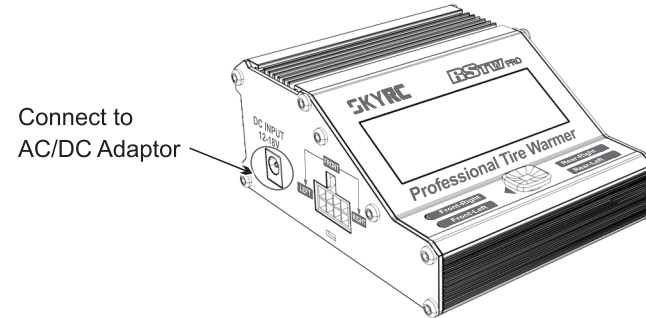

2. Using 4S LiPo Battery Pack

Also located on the right side of the tire warmer is XT60 port. You can power on the tire warmer with 4S LiPo battery.

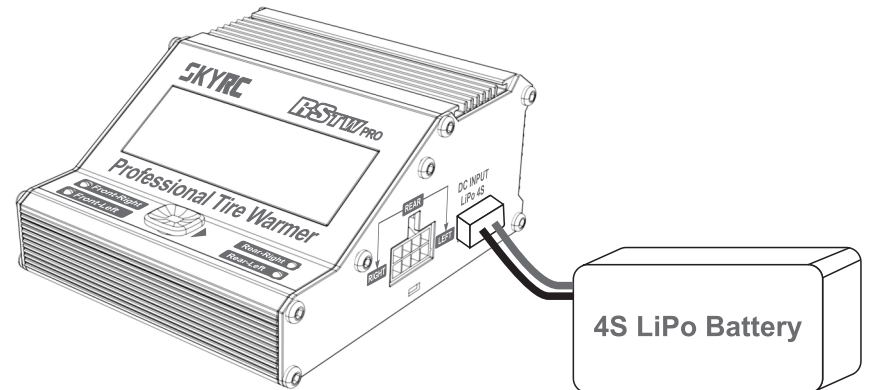

⚠ DO NOT CONNECT BOTH POWER SOURCE AT SAME TIME.

QUICK WARMING

This mode is easy to setup, good for standard use. You can change temperature during warming.

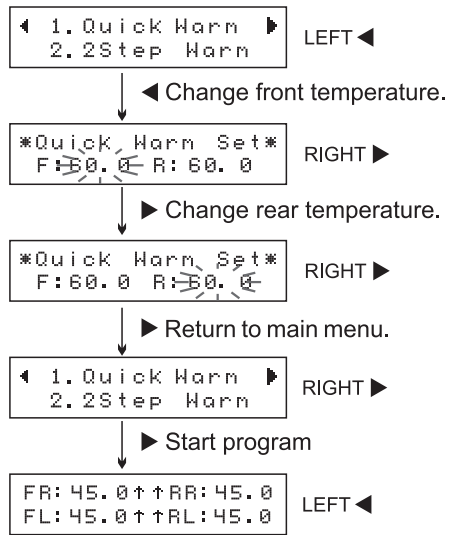

How to setup temperature
 ▲ Increase front or rear temperature.
 ▼ Decrease front or rear temperature.
 If you need extra hot warming for certain track or weather conditions, You can set 100°C/212°F by hit ▲ key once more when you reach to 80°C /176°F.

◀ You can see elapsed time during quick warming.
 Quick Warming 01:30
 It is recommended that the warmers are left on the tires for about 10 minutes, allowing the rubber to be heated uniformly and fully. Do not use for any periods longer than 30 minutes as this can damage the tire.

FR: 59.2 ↑ RR: 60.0
 FL: 59.6 ↑ RL: 59.9
 During the warming process, upward arrow "↑" means the temperature is going up. It disappears when the temperature is reached to target temperature and the LEDs will turn green.

▶ Quit out of Quick warming.
 ▲ or ▼ You can change temperature during Quick warming.

FR: 65.0 RR: ----
 FL: 65.0 RL: ----
 If you see "----" on the display, check warmers connection. On left display, rear warmers have bad connection or disconnected.

STEP WARMING

You can warm your tires by 2 step in this mode. It is convenient when you apply two different kinds of tire additives on your tires.

Three steps has one more warming step, all other functions are exactly the same as two steps warming.

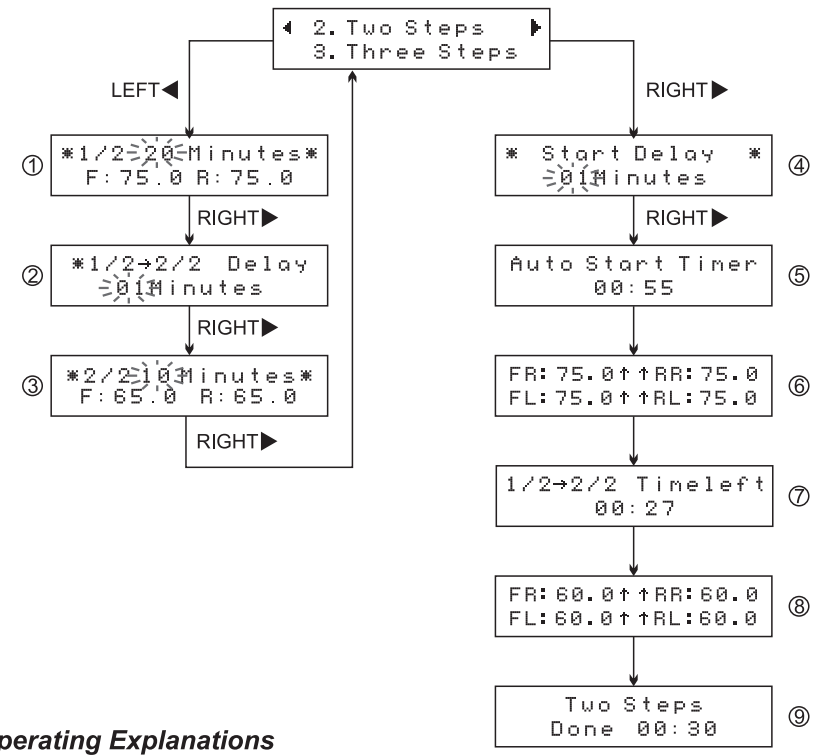

Operating Explanations

- ① ▲▼ Determine first step warming time.
 ▶ Set front and rear tires target temperature 20-80°C.
- ▲▼ Change front or rear temperature.
 ▶ Move to next set up
 ◀ Back to former set up
 If you need extra hot warming for certain track or weather conditions. You can set 100°C by hit ▲ key once more when you reach to 80°C.
- ② ▲▼ Determine delay time
 ▶ Move to next set up
 ◀ Back to former set up

- ③ ▲▼ Determine second step warming time.
 - ▶ Set front and rear tires target temperature 20-80°C
- ▲▼ Change front or rear temperature.
 - ▶ Move to next set up
 - ◀ Back to former set up



If you need extra hot warming for certain track or weather conditions, You can set 100°C by hit ▲ key once more when you reach to 80°C.
- ④ ▲▼ Set auto start timer
- ⑤ ▶ Skip count down.
- ⑥ **1/2 Step Warming**
 - ◀ You can check current step and elapsed time.
 - ◀ Back to former page
 - ▶ Quit from step warming.
- ⑦ **1/2 -2/2 Delaying**
 - ◀ You can check temperature or 1/2-2/2 delay time.
 - ▶ Skip delaying, move to 2/2 step warming
 - All LEDs will blinking in red during delay period.
- ⑧ **2/2 Step Warming**
 - ◀ You can check current step and elapsed time.
 - ▶ Quit from step warming.
- ⑨ **2 Step warming done**

All LEDs will blinking in green.

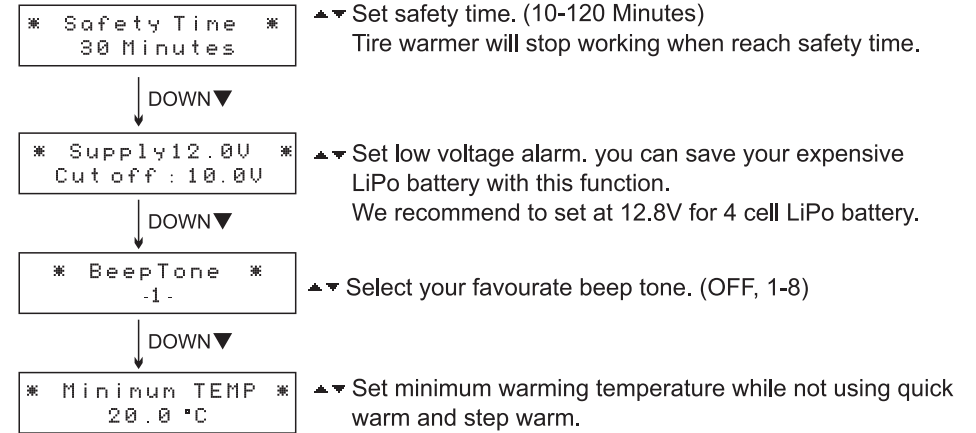
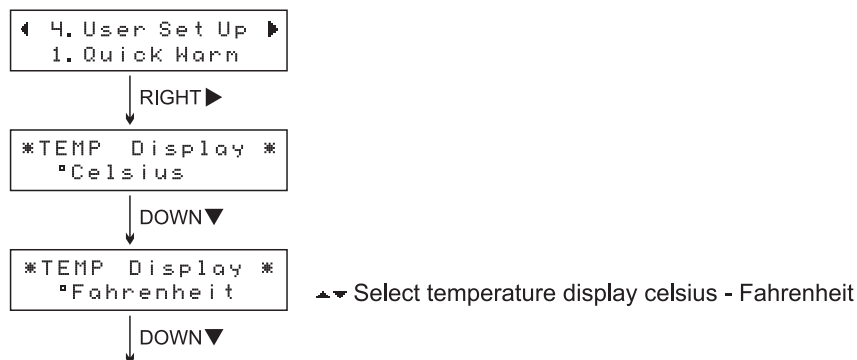
USER SET UP



OPTIONAL PARTS

Picture	Item Number	Item Name
	SK-600064-03	Warming Belt
	SK-600064-05	Warming Cup

CALIBRATION

You can calibrate your tire warmers with your thermometer.
Calibration is required when the temperature of tire warmers are changed.

With push ▲ key and hold, input DC power.

TEMP adjust mode
hand off please

Stop pushing ▲ button.

* Target TEMP *
OFF

▲▼ Determine target temperature for calibration.

LEFT ◀

FL will blink first.

FR: 69.2 RR: 66.5
FL: 68.8 RL: 71.0

Check the temperature of FL
with your thermometer

▲▼ Match the temperature to the value of thermometer



► Move cursor to next step.

Calibrate FR-RL-RR warmers as same way.

If you push ◀ key on FL, step-W will save all calibration data and will restart itself.

FACTORY RESET

You can reset the setting when you want to return all values to the original values.

With push ▼ key and hold, input DC power.

Factory reset
hand off please

Stop pushing ▼ button.

▲▼ Will ask you if factory reset.

Factory reset
NO ◀ ▶ YES

► Factory reset then goes to Main menu.

◀ Exit and goes to Main menu.

LIABILITY EXCLUSION

This tire warmer is designed and approved exclusively for use with for 1/10 size touring car's rubber tires stated in Instruction Manual. SKYRC accepts no liability of any kind if the tire warmer is used for any purpose other than that stated. We are unable to ensure that you follow the instructions supplied with the tire warmer, and we have no control over the methods you employ for using, operating and maintaining the device. For this reason we are obliged to deny all liability for loss, damage or costs which are incurred due to the incompetent or incorrect use and operation of our products, or which are connected with such operation in any way. Unless otherwise prescribed by law, our obligation to pay compensation, regardless of the legal argument employed, is limited to the invoice value of those SKYRC products which were immediately and directly involved in the event in which the damage occurred.

WARRANTY AND SERVICE

We guarantee this product to be free of manufacturing and assembly defects for a period of one year from the time of purchase. The warranty only applies to material or operational defects, which are present at the time of purchase. During that period, we will repair or replace free of service charge for products deemed defective due to those causes.

For any repair or replace service, please contact your dealer in the first instance, who is responsible for processing guarantee claims. This warranty is not valid for any damage or subsequent damage arising as a result of misuse, modification or as a result of failure to observe the procedures outlined in this manual.